

The Origin of Gravitation

Ionel DINU, M.Sc.

NYSICS Central Co., Ltd., Bucharest 060403, Romania

E-mail: *nysics_central@yahoo.com*

(Dated: January 17, 2007)

Copyright © NYSICS Central Co., Ltd.

Abstract

An object released from hand and falling to ground is such a common occurrence that it is not even perceived as a phenomenon of nature. Nonetheless, the accelerated motion of such an object has all the characteristics of a physical process and at its origin is the most ubiquitous force known in science. The universality of gravitation was demonstrated in the theories of Nicholaus Copernicus, Johannes Kepler and Isaac Newton. The latter's insight of explaining the movement of celestial objects by the same force that acts near the surface of the Earth and causes the fall of bodies was an important step that greatly expanded our knowledge. Notwithstanding the huge efforts directed towards elucidating the nature of gravitation, no satisfactory results have been attained and no meaningful theory has been proposed so far. It is not quantitative evaluations or mathematical methods that are in want, but a picture that can be comprehended qualitatively in the first place. Only after such a qualitative picture has been found can it be hoped that a meaningful mathematical theory be constructed. The unerring methods of calculus would then make possible finding results whose physical interpretation would point to phenomena possible to occur, giving in the same time the conditions that are needed for them to occur. The present work endeavors to propose such a theory and shows that the gravitational force is essentially Archimedic in nature, acting on all bodies immersed in the vast ocean of aether.

Keywords: gravitation, aether, radiation pressure, mass, inertia

Introduction

Many are the criticisms that can be presented to the theory of gravitation accepted today. The most important one is that the gravitational force is considered in today's interpretation to be generated by the substance that constitutes the bodies. This is equivalent with the statement that matter acts as a source of gravitation, having an intrinsic power to attract matter situated at some distance apart. The difficulty in accepting such a theory rests not only in that there is no a priori reason why matter should be endowed with such a power, but also in that there is no credible demonstration of such a fact. Further, the belief that is sometimes encountered according to which this power is transmitted instantaneously through space confers to the theory an action-at-a-distance character that makes it even more open to objections.

The explanation that is currently given for the dependence of the gravitational field intensity of a body M on the inverse square of the distance from its center is another questionable issue. All demonstrations are based on the statement that the flux of the intensity of the gravitational field through a closed surface containing the body is constant. While mathematical calculations based on this assumption indeed confirm the inverse square dependence with the distance, the physical interpretation of the notion of gravitational field intensity flux through a surface remains unclear. So little is known about the nature of this flux that it is not even determined whether it is static or it is meant that something is continually emitted from or coming to the body generating the gravity field. Sometimes explanations are encountered where analogies are used in order to help the reader understand the proposed picture, although it is evident that what is exactly happening in reality is not fully grasped. This kind of perpetuated obscure interpretation of gravitational field flux is another proof that the notion it is derived from, the gravitational force, is still one of the least comprehended topics of the present science.

Lastly, a few comments will refer to the factors in Newton's law of gravitation

$$F_G(r) = G \cdot \frac{M \cdot m}{r^2} \quad \text{Eqn. 1}$$

as they bear a tremendous importance on the interpretation of the notion of density of matter. Newton mentioned the concept of density of matter when he spoke of the quantity of matter Q_M contained in a body. He stated:

“The quantity of matter is the measure of the same, arising from its density and bulk conjunctly.” [1]

Consistent with his definition, he put forward the law of gravitation as follows:

“There is a power of gravity tending to all bodies, proportional to the several quantities of matter which they contain.” [2]

In many of the explications regarding this law, one of which is quoted at the end of this introduction, Newton states that the gravitational force between two bodies is made up out of the gravitation towards the particles of which the bodies are composed. From this statement it follows that the more particles the bodies contain the stronger the force of gravitation is, which is equivalent to saying that the gravitational field intensity of a body is proportional with the number of particles that are contained in its volume. Thus, following strictly Newton's line of reasoning, the notion of quantity of matter comes to represent simply the number N of particles making up the respective body. Related to this there is another aspect to be considered. Take, for simplicity, the limit situation when each of the interacting bodies is comprised of only one particle. In this case, although the number of particles is equal in the two bodies, the gravitational field will be stronger on the part of the particle of bigger volume, on account that the quantity of matter Q_M is greater in its case. It follows then that the total quantity of matter Q_M in a body is given by the product of the number N of particles with their respective volumes w . Using Newton's definition for the quantity of matter, the density is obtained as:

$$d = \frac{N \cdot w}{V} \quad \text{Eqn. 2}$$

where, again, N is the total number of particles of volume w that are aggregated into the macroscopic body of volume V .

It can be seen from eqn. 2 that the density of matter is dimensionless, representing the fraction of the volume of the body occupied by the atoms of the substance. This is in a striking contradiction with the present definition for the density of matter, which is measured in SI in units of Kg/m³. As it is well known, the unit of kilogram comes into the definition of density of matter because the particles making up a macroscopic body are not counted -as it should be, according to eqn. 2- and their total volume $N \cdot w$ related to the volume V of the macroscopic body that they form. Instead, the weight of the object is compared with that of another body taken as unit (and called kilogram). It is important to emphasize here that this procedure of comparing the bodies with the aim of finding the quantity of matter that they contain is useless and has no justification. Useless, because the conventional unit for the quantity of matter, the kilogram, is in itself not defined with respect of the quantity of matter that it supposedly represents. Therefore, the procedure of comparing a body with the kilogram in order to find such an absolute physical quantity as the quantity of matter contained in it will not offer any relevant information. This can only give, in the best case, a relative physical quantity. That the comparison with the kilogram is unjustified comes from the fact that this relative physical quantity is obtained by weighting and this process involves the action of the gravitational force which it was

shown in the foregoing discussion that is a phenomenon whose nature and way of action are not elucidated.

But there is another argument that shows the uselessness of having a physical unit as the one defined today as the kilogram. It is often stated that the quantity of matter in a body is proportional with its weight and that, since the proportionality constant is the same for all the objects, the quantity of matter contained in a body can be found by comparing its weight with that of a body considered as unit. The quantity of matter found by this procedure is called mass. What is, however, overlooked in this reasoning is that the same body placed in the interstellar space will show no evidence of the property of mass, although the quantity of matter obviously remains unchanged. Hence, mass is not an intrinsic property of a body. Only upon accelerating it the inertia effect comes into play and some resistance -as Newton characterized it- to the change of speed is detected. But this only comes to show again that what is called mass is a thoroughly dynamical effect and that it should be treated as such. This character of mass implies that the mass derived from weighting is also not an intrinsic property of the body, but the result of a dynamical effect that has not been evidenced until now and needs to be elucidated. This dynamical effect, to be elaborated on in more detail later in this work, may in its turn be partially determined by some intrinsic property of the body, which one more time comes to prove that their nature is totally different. Mass is an effect while the quantity of matter is a property of the body and these two notions cannot be made identical with each other. Hence follows the inadequacy of using the kilogram in order to assess intrinsic properties of bodies such as density of matter.

Since the density of matter of a body as defined in eqn. 2 is not dependent on the kilogram, the conventional unit, it will be called the absolute density of matter of the respective body.

Returning to Newton's statement that the attraction force between two bodies is proportional with the quantity of matter that they contain, it follows that, if we want to reflect this statement in mathematical terms in an accurate manner, eqn. 1 should be rewritten as

$$F_G(r) = G' \cdot \frac{\Omega \cdot \varepsilon \cdot N \cdot w}{r^2} \quad \text{Eqn. 3}$$

where Ω and N represent the total numbers of particles that make up the bodies M and m respectively, and ε and w are the volume of the constitutive particles that make up the respective bodies.

The absolute density of matter D of the body M can be expressed by an equation identical with that used in the case of body m. For this case, eqn. 2 becomes,

$$D = \frac{\Omega \cdot \varepsilon}{W}$$

where W is the total volume of body M .

Using the equations for the absolute densities of matter, eqn. 3 for the gravitational force becomes

$$F_G(r) = G' \cdot \frac{D \cdot W \cdot d \cdot V}{r^2} \quad \text{Eqn. 4}$$

The significance of writing Newton's law as above will be seen in the following discussion, when the equation obtained for the force of gravitation will be shown to resemble eqn. 4 more than eqn. 1. This will come to offer further support for the argument made in this section regarding the notion of density of matter.

The theory of gravitation was in an incipient state until Newton transformed Kepler's equations from kinematical into dynamical ones. In its turn, Newton's initial theory acquired the present form and interpretation by a long process through which its meaning was partly deviated. It is surprising to find that the understanding of gravitation, as imperfect as it must have been in Newton's time, was vastly different from the one held today. Eloquent illustrations that prove this can be found in the very words of the author of *Principia* and *Opticks*:

"You sometimes speak of gravity as essential and inherent to matter: pray do not ascribe that notion to me, for the cause of gravity is what I do not pretend to know" [3].

"That gravity should be innate, inherent and essential to matter, so that one body may act upon another at a distance through a vacuum, without the mediation of anything else, by and through which their action and force may be conveyed from one to another, is to me so great an absurdity, that I believe no man who has in philosophical matters a competent faculty of thinking, can ever fall into it. Gravity must be caused by an agent acting constantly according to certain laws; but whether this agent be material or immaterial, I have left to the consideration of my readers" [4].

"And to show that I do not take gravity for an essential property of bodies, I have added one question concerning its cause, choosing to propose it by way of a question, because I am not yet satisfied about it for want of experiments" [5].

It can be easily seen from the above quotes that, contrary to the common belief held today, nowhere was the gravitational force conceived as originating in the substance constituting the material bodies, while its action-at-a-distance character was not even mentioned. That the nature of this force was never fully grasped and eluded the comprehension of even its author are undeniable facts. This is shown again in the final quote below, which will also prove helpful in comparing the present understanding of

gravitation with that of Newton's of more than 300 years ago and realize how little advancement, if any, has been made during this period [6]:

“Hitherto we have explained the phenomena of the heavens and of our sea by the power of gravity, but have not yet assigned the cause of this power. This is certain, that it must proceed from a cause that penetrates to the very centers of the sun and planets, without suffering the least diminution of its force; that operates not according to the quantity of the surfaces of the particles upon which it acts (as mechanical causes use to do), but according to the quantity of the solid matter which they contain, and propagates its virtue on all sides to immense distances, decreasing always in the duplicate proportion of the distances. Gravitation towards the sun is made up out of the gravitations towards the several particles of which the body of the sun is composed; and in receding from the sun decreases accurately in the duplicate proportion of the distances as far as the orb of Saturn, as evidently appears from the quiescence of the aphelions of the planets; nay, and even to the remotest aphelions of the comets, if those aphelions are also quiescent. But hitherto I have not been able to discover the cause of those properties of gravity from phenomena, and I frame no hypotheses; for whatever is not deduced from phenomena is to be called an hypothesis; and hypotheses, whether metaphysical or physical, whether of occult qualities or mechanical, have no place in experimental philosophy. In this philosophy particular propositions are inferred from the phenomena, and afterwards rendered general by induction. Thus it was that the impenetrability, the mobility, and the impulsive forces of bodies, and the laws of motion and of gravitation, were discovered. And to us it is enough that gravity does really exist, and act according to the laws which we have explained, and abundantly serves to account for all the motions of the celestial bodies, and of our sea”.

Aether Permeation of Bodies

In a work published recently [7] it was demonstrated that the electric charges that make up the electric current flowing in a wire entrain the aether that exists outside and permeates the inside of the material of the conducting wire. In this theory the aether was assigned the minimal property of a gas obeying the laws of fluid dynamics and this led to very accurate explanations of the interactions between flowing electric currents. The same phenomenon of aether drag by the electric charges pointed to the conclusion that an oscillatory electric current gives rise to mechanical oscillations of the aether, leading to a theory free from the inconsistencies and the ad hoc conventions of the electromagnetic theory of today.

Further analysis of the facts mentioned above leads to some very significant consequences. For the aether that exists outside and permeates the inside of the material of the conducting wire, and of any material object in general, must exist in a state of definite pressure. This aether pressure can be uniform, but can also vary from place to place. And if such a variation exists and a gradient of aether pressure is present, then a body left to itself and not acted on by any force, will be pushed in the opposite direction of the gradient. The driving force is Archimedic in nature, resembling that of buoyancy.

Mathematically, this can be expressed as follows. In Fig. 1, $dV = dx \cdot dy \cdot dz$ is an infinitesimal volume of an object of total volume V that is situated in a region where an aether pressure gradient exists. The force due to the aethereal pressure difference acting on dV parallel to the x- direction is:

$$dF_{ae} = p \cdot dy \cdot dz - \left(p + \frac{\partial p}{\partial x} \cdot dx \right) \cdot dy \cdot dz = -\frac{\partial p}{\partial x} \cdot dx \cdot dy \cdot dz = -\frac{\partial p}{\partial x} \cdot dV \quad \text{Eqn. 5}$$

As similar expressions are obtained for the y- and z- directions, the general form of the force is:

$$d\vec{F}_{ae} = -\left(\frac{\partial p}{\partial x} \cdot \vec{i} + \frac{\partial p}{\partial y} \cdot \vec{j} + \frac{\partial p}{\partial z} \cdot \vec{k} \right) \cdot dx \cdot dy \cdot dz = -\nabla p \cdot dV \equiv \text{grad}(p) \cdot dV \quad \text{Eqn. 6}$$

where \vec{i} , \vec{j} and \vec{k} are the unit vectors of x-, y- and z- directions, respectively.

Integration in the approximation that $\text{grad}(p)$ is constant throughout the volume V of the object gives

$$\vec{F}_{ae} = -\nabla p \cdot V \quad \text{Eqn. 7}$$

which can be considered the most general formulation of Archimede's principle, as it may be used as a starting point in obtaining the formula for buoyancy. [8]

In his Opticks of 1717, Newton questioned whether this may not be the real cause for which we see bodies attracted to the Earth or to other massive bodies of the heavens. Here are his words:

“Is not this medium (the aether) much rarer within the dense bodies of the Sun, stars, planets and comets, than in the empty celestial spaces between them? And in passing from them to great distances, does it not grow denser and denser perpetually, and thereby cause the gravity of those great bodies towards one another, and of their parts towards the bodies; every body endeavoring to go from denser parts of the medium towards the rarer?”

It can be seen from the above that Newton hinted at the existence of an aether gradient around any massive body and hypothesized that the tendency of objects to move towards

these massive bodies may be explained by a theory involving the force of buoyancy in the aether.

The Origin of Aether Pressure Gradient

It is unfortunate that Newton did not seem to find in its time the appropriate means to confirm this theory. It is even more difficult to understand why his conjecture, far from being utterly implausible, was never neither proved nor disproved, but left aside as pure speculation. In the following discussion it will be shown that this theory is an accurate description of what happens in reality in phenomena known as gravitation and that, indeed, an aether pressure gradient is present around a massive body. The origin of this gradient is not, however, the one imagined by Newton, who believed that the aether is pushed out of, or much rarer in, the massive bodies due to the huge inner density of their matter, for this would not explain the existence of a gradient of aether pressure in the regions exterior to the surface of the respective body.

Since the aether is nothing more than matter in a very fine state of aggregation [7], the origin of the aethereal gradient surrounding a massive body is to be found in the total radiation emitted by the respective body. This radiation, currently known as thermal or electromagnetic radiation, was shown to be essentially mechanical oscillations of the aether [7]. The effect of the emission of radiation by a hot body is to exert a pressure, known as radiation pressure, on the surrounding aether that has the effect of pushing the aether away from the source of radiation. The aether is thus both the substance conveying the oscillations and the subject of the wave pressure, in the same manner in which air acts with respect to the mechanical waves (sound) that it conveys.

The phenomena related to the radiation pressure with electrical origin were predicted by James Clerk Maxwell [9] and were further studied by John Henry Poynting [10]. Maxwell was a firm believer in the existence of aether and of its role in transmitting the electric oscillations through space. Poynting suggested that the radiation pressure of the Sun acts on a small body in the sense that it diminishes the Sun's gravitational pull. He hinted at the interplay between the two forces and at the existence of a critical size of a body at which the former may overcome the later, thus liberating the body from the pull of the star. In spite of the fact that both authors considered only the effects of the pressure of radiation on macroscopic bodies and overlooked the possibility that the aether may as well be affected by it, their studies remain important references on this subject.

The present work suggests that it is the radiation pressure of a thermally active hot body that is causing the aether to be pushed away not only from the volume of the

respective body, but also from the regions beyond the limits of its geometrical surface. This expulsion of the aether by the hot body is total only within a finite radius from the center of the body, beyond which the repulsion becomes partial. This translates into an aethereal pressure that is low at the surface of the hot body, lowest at its center, rising gradually with the distance from the center until it reaches a constant value p_i . In these circumstances, any object situated in such a region of aether pressure gradient will be pushed by the force given in eqn. 7 in the direction opposite of the gradient, i.e. towards the center of the hot body. At greater distances from the hot body where the radiation pressure becomes small, the aether pressure reaches its uniform value p_i . This constant value of aether pressure translates into a zero pressure gradient, i.e. to a zero gravitational force. When the same object is placed in such a region no force is felt.

It is known that if Π_0 is the total energy of radiation emitted by a hot body in unit time, then the intensity of the radiation decreases, in absence of any attenuating cause, with the inverse square of the distance:

$$J(r) = \frac{\Pi_0}{4 \cdot \pi \cdot r^2} \quad \text{Eqn. 8}$$

As it was discussed elsewhere [7], the electromagnetic radiation represents mechanical waves of the aether. The pressure of such a wave is given by [11]:

$$p_{rad}(r) = \sqrt{J(r) \cdot Z_C} \quad \text{Eqn. 9}$$

where Z_C represents the characteristic (or specific) impedance of the oscillating medium. Using eqn. 8, it can be seen that the pressure of radiation has the form:

$$p_{rad}(r) = \frac{\Gamma_0}{r} \quad \text{Eqn. 10}$$

where the constant Γ_0 is given by,

$$\Gamma_0 = \sqrt{\frac{\Pi_0 \cdot Z_C}{4 \cdot \pi}} \quad \text{Eqn. 11}$$

The condition of mechanical equilibrium between the aether and the radiation of the hot body translates into the condition of equality between the involved pressures at any point of space

$$p_{rad}(r) = \Delta p_{ae}(r) \quad \text{Eqn. 12}$$

where $\Delta p_{ae}(r)$ is the decrease in the aether pressure due to radiation at point r of space.

From eqn. 10 it follows that:

$$\frac{\Gamma_0}{r} = p_i - p(r) \quad \text{Eqn. 13}$$

where p_i , a constant, is the absolute aether pressure in the regions far away from the radiating body and $p(r)$ is the absolute aether pressure at the distance r from its center.

The equation of dependence of aether pressure with the distance from the radiating body becomes:

$$p(r) = p_i - \frac{\Gamma_0}{r} \quad \text{Eqn. 14}$$

The gradient of the aether pressure is obtained from the above equation as

$$\nabla p = \frac{\Gamma_0}{r^2} \quad \text{Eqn. 15}$$

The Equation of Gravitational Force

Equation 7 was obtained by assuming that the pressure gradient of the aether acts on the total volume V of the body. The fact that the internal structure of a macroscopic body is not continuous was overlooked in the demonstration. The various experiments of thermal dilatation, mechanical compression, X-ray diffraction, Proust's law of definite proportions, Dalton's atomic theory, are but a few examples of evidence ascertaining the particulate constitution of matter. These also prove that the space inside the volume of a macroscopic body is of two types: one is that occupied by the atoms of the substance tied to each other by chemical bonds, and one is represented by the interstitial space filled by aether.

To properly account for this particulate structure of the bulk, a quantity need to be employed that gives a measure of the volume occupied by the atoms of substance out of the total volume of space that they occupy when aggregated into a macroscopic body. This quantity has been defined in eqn. 2 as the absolute density of matter.

Then, if f is the force due to aether pressure gradient acting on an atom of volume w , the total force F_{ae} acting on the macroscopic body made up from a number N of these atoms is, with eqn. 7:

$$F_{ae} = \sum_{i=1}^N f_i = -\sum_{i=1}^N \nabla p_i \cdot w_i \quad \text{Eqn. 16}$$

If the aether pressure gradient is the same for all the atoms of the body, the total force can be obtained as:

$$F_{ae} = -\nabla p \cdot \sum_{i=1}^N w_i = -\nabla p \cdot N \cdot w = -\nabla p \cdot d \cdot V \quad \text{Eqn. 17}$$

where eqn. 2 was used.

Eqn. 17 is a more exact formulation of eqn. 7 in that it takes into account the fact that not all the volume V of a macroscopic body is subject to the aethereal Archimedic force, but only a fraction d of it representing the total volume occupied by atoms of matter.

Considering eqn. 17 together with eqn. 15 and eqn. 11, the gravitational force can be expressed by

$$F_{ae} = -\sqrt{\frac{\Pi_0 \cdot Z_C}{4 \cdot \pi}} \cdot \frac{d \cdot V}{r^2} \quad \text{Eqn. 18}$$

which is the final form for the gravitational force exerted on an object of macroscopic volume V , absolute density of matter d , and situated at distance r from a body of radiating power Π_0 , the radiation being conveyed by aether having characteristic impedance Z_C .

What is remarkable regarding eqn. 18 is that it confirms the proportionality of the gravitational force with the inverse square of the distance from the center of the body as stated in Newton's law of gravitation. This dependence, however, is shown to have its origin in the variation of the radiation pressure with the inverse of the distance from the radiating body and is therefore not due to the constant value of a certain flux of gravitational intensity field mentioned in the introduction. It is also worth mentioning that eqn. 18 is valid provided that the force F_{rad} due to the radiation pressure on the object of volume V is negligible compared to that due to the Archimedic effect F_{ae} of aether pressure gradient. This condition of

$$F_{rad} \ll F_{ae}$$

translates into

$$\frac{F_{rad}}{F_{ae}} \ll 1$$

or, equivalently,

$$\lim \frac{F_{rad}}{F_{ae}} \rightarrow 0$$

Since, for the same radiating power Π_0 of the hot body, F_{rad} is proportional with the surface A and F_{ae} with the volume V of the body, the above condition is fulfilled when

$$\lim \frac{A}{V} \rightarrow 0$$

For an object having the form of a sphere of radius R , the relation between the volume and its surface is given by

$$V = \frac{1}{3} \cdot A \cdot R$$

so that the above limit becomes, omitting the constants involved,

$$\lim \frac{1}{R} \rightarrow 0$$

From this it can be seen that the force due to radiation pressure becomes the more negligible compared to that due to aetherial pressure gradient the bigger the radius of the body of volume V . Conversely, it can be inferred from the above that, for objects of small radius, the force due to radiation pressure can overcome that due to the aether pressure gradient that the same radiation generates. This will correspond to the case in which an object would be driven by the radiation it receives, moving against the gravitational field that surrounds it. This result is significant in that it comes to supplement the observations of Poynting referred to above.

Notwithstanding the similarity of eqn. 1 and eqn. 18 regarding their variation with the distance r , it is obvious that they differ entirely when it comes to other variables. It can be observed that the gravitational field generated by a body is not a function of the mass of the respective body (present day view), neither of the quantity of matter existing in that body or of the density at which a matter exists within its volume (Newton's conjecture), but it is only a rising function of the total radiation power emitted by the respective body.

It can also be seen now that the equation for the gravitational force resembles eqn. 4 more than eqn. 1 in that the force is proportional not with the mass of the second body, but with its volume V and the absolute density of matter d . It is important to note that the absolute density of matter d is not the conventional one defined in terms of the kilogram, but it is that defined in eqn. 2, independent of the kilogram or of any other similar conventional unit.

General Implications for Astronomy

It was stated in the foregoing discussion that the aether pressure gradient surrounding a body is generated by the total radiation emitted by the respective body. It follows from this that the gravitational field of a body is in fact maintained at the expense of the internal energy of the hot body. When the later is exhausted, the former also becomes nil.

A celestial body in a cold state does not exert any pressure on the aether that permeates its volume. The aether fills the interstices of the volume of the respective body at a pressure equal with the aether pressure p_i of the interstellar space and no aether pressure gradient exists around it (Fig. 2). The consequence that follows is that a cold body does not generate around itself a gravitational field, being subject only to the gravitational fields of other hot objects. This further leads to the conclusion that two cold

bodies cannot exert gravitational forces towards each other, as there is no source of radiation to generate the necessary aether pressure gradient. Stated equivalently: There is no situation in Universe where two cold, thermally inactive bodies form a bound system, having closed orbits and gravitating around each other.

In the case of a thermally active celestial body that is in a hot state and emitting radiation, the aether is pushed away from within its volume and beyond the geometrical limit of the body, thus creating around itself a region of lower aether pressure than p_i (Fig. 3). The hot body practically impinges on the aether radially in all directions and creates around it a region of low-pressure aether. The gradual raise in the aether pressure from the lowest value within the body to the interstellar value at great distances leads to the existence of an aethereal pressure gradient that will act as an Archimedic force on any body, cold or hot, that is placed in this region.

The star of our system is one familiar example that can provide evidence for the theory advanced here. The Sun is the most powerful radiating body of our planetary system, having a temperature beneath the surface estimated at unimaginable values of millions of K [12]. This generates an aethereal pressure gradient extending 6470 solar radiuses, or 4503 millions km from its center, up to the orbit of Neptune and beyond. However, when the thermal activity of the Sun will cease and it will turn into a cold object, its gravitational field will become zero. As the thermal death of the Sun will presumably take place in a gradual manner, the diminishing strength of its gravitational field will bring about the loosening of the pull on the planets of the solar system. They will escape one by one to other systems where, most probably, will be entrapped. The Sun will then become a celestial object like a simple planet that will be subject to the gravitational force of other stars.

The case of Jupiter is very similar with that of the Sun. Actually Jupiter can be considered the second sun of our solar system and, with its sixty-three moons, forms a small planetary subsystem within the solar system. The temperature of the planet is not known, but its gaseous state could be determined and helium and hydrogen were found to be the most abundant elements, in a striking similarity with the Sun. Based on the idea advanced in the present work that the gravitational field of a body is generated by the thermal activity of the respective body, it can be said that Jupiter is in a stage of evolution following that of a hot star and has a very high interior temperature, second probably only to that of the Sun.

This relative similarity between the two largest celestial bodies of our system, considered along with the theory advanced in this work may give a good account for the existence of the belt of asteroids situated at a distance between the two. Indeed, it is to be

expected that such a situation occurs since, as it was shown before, the force deriving from the aethereal pressure gradient F_{ae} is negligible compared to that due to radiation pressure F_{rad} in the case of bodies of small radius. As only the later force gives significant effects, there is a certain distance between Sun and Jupiter where the radiation pressure coming from the two radiating bodies generate equal but opposite forces on a small body situated between them. Any small body that would be pushed away by the solar radiation is pushed back by the radiation from Jupiter, resulting in the formation of an agglomeration of small celestial bodies between the Sun and Jupiter. Due to the movement of Jupiter in a closed orbit around the Sun, this agglomeration takes the form of the mentioned belt of asteroids famous for resembling with a border that marks the limit of the realm of the inner planets and the beginning of that of the outer planets of the solar system.

Supplementary evidence for the hypothesis of gravitational field generated by radiation can be found in the case of our planet. Earth is known as a planet with a small solid crust under which matter exists at very high temperatures, as can be ascertained from the temperatures of the lava expelled during the volcano eruptions. The gravitational field that Earth generates due to its radiation power explains not only the existence of the force of attraction for bodies in the neighborhood of its surface but also the existence of its natural satellite. Moon is a relatively cold celestial body that has most probably been captured in the past [13], when the temperature of our planet was much higher and its gravitational force much stronger and more extended spatially. At its actual radiating power the Earth develops a gravitational field that extends over 60 earth radiuses, or 384,000 km from its center, which is the mean orbiting distance of the Moon.

There is an inconsistency in the explanation given today for the strong gravitational fields of Jupiter and of the Sun in that they are held to be due simply to the quantity of matter present in these bodies. Based on these suppositions, the mean density of matter is estimated at 1.410 g/cm^3 for Sun and at 1.314 g/cm^3 for Jupiter. [12, 14] These values are, however, very hard to accept for there is an obvious inconsistency between the high temperatures of these celestial bodies and the very low temperatures that are required for the condensation of matter into bulk of such a density. Water, for example has a density of 1.00 g/cm^3 and evaporates at merely 373.15 K. The millions of K that the temperature of Sun is estimated at would transform any element into gaseous matter of very low density. While it is acknowledged that Sun is partially made up of low-density gaseous matter, accounting for the value of its estimated mean density reclaim that the density of matter in the Sun's core be very high. This may look plausible as the huge gravitational force of the Sun can be conceived to lead to high pressures for the matter within its

volume. However, it is too often forgotten the experimental finding that gases, and indeed any kind of matter, cannot be compressed into a body of high density unless its temperature is lowered below a critical value. The experimental data show that application of pressure to a gas does indeed diminish its volume and leads to the increase of its temperature. But if detailed analysis is done by taking out energy to keep the temperature constant during compression, then a family of curves for various temperatures can be obtained and a volume-pressure phase diagram of any element can be drawn. The isotherms in such a diagram never intersect and are more distanced from the axes the higher the temperature. [15] This represents strong evidence that the volume of the gas, and implicitly its density, can never reach values equal to those of liquid or solid state at low temperatures, much less the purported ultra-high densities of a super-condensate within the volume of a star whose temperature is millions of K.

The estimated mean density in the case of Earth is 5.52 g/cm^3 . This led, in conjunction with other aspects like the existence of the geomagnetic field, to the opinion that the core of the planet is made of iron in a liquid state. The impressive amount of work directed at the elucidation of the behavior of iron and its compounds at extremely high pressures and temperatures is the result of such a conjecture. [16] Unfortunately, there is a considerable amount of uncertainty in the present-day iron phase diagram as it is drawn for such extreme values by extrapolations and calculations based on formula more or less applicable in such situations. To this it must be added that the true values of the temperatures of the Earth interior as well as the true compositions of the mantle and core are still in dispute and chances are to remain so long time from now. In these circumstances, it is neither legitimate nor scientific to exclude the possibility that the core of the Earth be in fact in a gaseous state, the most probable state of a reminiscent star-like hot object that our planet obviously was at a time. The difficulty is, however, that, if this is true, then the value of the mean density of earth will be much lower than the one estimated from the theories held today, and this would prove that they are flawed. In the same time, the theory advanced in the present work has no inconsistency whatsoever with the core of the Earth being in a gaseous state. On the contrary, since such circumstances would account very well for the emission of radiation necessary to create an aether gradient, and therefore a gravitational field, around the planet.

Spectral Radiation of Hot Bodies. Dark Stars

The radiation coming from Sun was found to have a good agreement with the spectral radiation curves obtained by O. Lummer and E. Pringsheim for hot bodies at a given

temperature [17]. As a result of the good fit of the solar spectral radiation curve with that of a hot body with a temperature of 5800 K, the Sun temperature was assigned this value [18]. However, it is hardly conceivable that this is the true temperature of the star of our system and, in acknowledgement of this, present science calls the temperature found in this way effective temperature. As it was mentioned before, the central temperature of the Sun is estimated at several millions K and this unusual difference in the values of the temperature of the Sun points to a significant fact to be considered. Thus, while the spectral curve for 5800K, with its inferior cut-off wavelength, corresponds to an upper limit for the frequency of the radiation emitted by the Sun, on account of the Sun's much higher temperature, it should be expected that thermal radiation of much higher energy exists within the volume of the Sun. In these circumstances, how are the two emission mechanisms to be reconciled? And if this very high frequency radiation from Sun exists, where is it?

It was shown in the foregoing discussion that, generally, a hot celestial body will expel the aether within its volume up to a limited radius R_e and, beyond that, partial repulsion occurs, the aether reaching its interstellar values of pressure at great distances from the respective body.

The present work asserts that radiation of higher frequencies exists but it is emitted by the matter existing within the volume of the body up to the radius R_e . This results in the radiation coming from matter within the volume R_e not being conveyed to the outer regions due to inexistence of the aether as a transmitting medium, while only radiation effectively impinging on the aether is transmitted through. The aether existing in the volume between R_e and R_0 (the radius of the outer geometrical limit) in a state of decreased pressure is able to convey radiation emitted by matter existing there to the outer regions. Hence, according to this picture, the measured solar spectrum corresponding to a hot body of only 5800 K is due to the thermal radiation emitted by matter situated between R_e and R_0 within the volume of the Sun. To this is to be added the component of high energy X-ray radiation.

There is, along these arguments, one extreme situation that may occur when the radiation of a celestial body is extremely strong: that in which the radiation of the body repels the aether totally from within its volume up to a certain radius R_e ($R_e \geq R_0$). In this case the whole radiation will be prevented from reaching the outer regions since the aether is not present within the volume of the radiating body to convey the oscillations, and only the very high frequency radiation that impinges on the aether is transmitted further to the outer regions.

It may be easily seen that the result of such a situation will be an immense aethereal

gradient, corresponding to an immense gravitational force. In the same time, in spite of having huge thermal activity, no radiation would be detectable from such a celestial body, except the very high frequency radiation, the only one in contact with the aether and thus conveyable to the outside regions. This situation is in a striking concordance with the experimental observations of ULXs (ultra-luminous X-ray sources) that are sometimes included in the class of intermediate black holes. [19] The case of ULXs is still under study but whatever these objects may turn out to be, it can be safely stated that there is at least a concordance between the situation when $R_e \geq R_0$ and the object described as a dark star, the precursor concept of the black holes [20]. The limit zone would correspond to the modern notion of event horizon and its radius to the Schwarzschild radius R_s so that

$$R_e = R_s$$

It can be seen that in the picture here advanced the notion as well as the origin of such a celestial object gains a more straightforward physical interpretation.

Newton's Second Law of Motion. Significance of Inertia

It was discussed in the introduction that mass cannot be considered an intrinsic property of an object, being essentially a dynamical effect. As Newton's second law of motion makes use of the concept of mass, necessity arises of discussing this law in order to understand the new consequences deriving from the view advanced in this work.

The first observation to be made is that, although this law is usually written as

$$F = m \cdot a \quad \text{Eqn. 19}$$

it is often overlooked the fact that m should be written instead m_i . Using m_i is important since, in the simplest formulation of the law, free of any unnecessary assumptions and derived solely from what experiments show, this parameter should be taken to represent only a constant of proportionality. This is consistent with, and preserves the intrinsic value of, Newton's second law which says precisely this, that there is a relation of proportionality between the force applied to a body and the acceleration that results, the involved constant of proportionality referring to the effect known as inertia. Rightly considered by Newton to arise from a kind of resistance, inertia is an effect of strictly dynamical nature and it is always desirable to write m_i instead of m to always remember that the constant of proportionality refers to it. To completely show the significance of this quantity it should be, and will be called henceforth, constant of inertia. Given its obvious dynamical origin, this constant is often wrongly ascribed to a static property of the accelerating object when instead it should be linked to a dynamical

effect. It is true that this dynamical effect may, in turn, depend on a certain intrinsic property of the object but they are, as already stated before, different physical quantities that should not be confused with each other. In particular, the inertia effect should not be ascribed to the quantity of matter and the proportionality constant made equal to it and called mass, for it was shown that the quantity of matter and mass refer to notions of different nature.

The omission of the concept of inertia from Newton's second law is the cause of another misunderstanding regarding its interpretation in that the term $m \cdot a$ was deprived from its meaning of being just a reaction force to the action force F . Indeed, since it is obvious that a body cannot accelerate by itself, it has to be considered in relation to another one that provides the force. Eqn. 19 is then correctly written as a relation between an action and a reaction force as,

$$F_{action} - m_i \cdot a_{reaction} = 0 \quad \text{Eqn. 20}$$

If analysis is made on the situation of a body in a Torricellian vacuum, it is found that the aether and the substance of the body are the only entities present. This is the most simplified case that can be objectively considered, since all the other possible interactions between the body and other objects are removed. Furthermore, in the absence of any aethereal pressure gradient, the effect of a force applied to the body will be to bring it from the state of rest to one of motion. This is exactly the situation that eqn. 20 describes mathematically.

In these circumstances, the reaction force $m_i \cdot a_{reaction}$ that a body manifests when acted upon by a force F_{action} can be ascribed exclusively to the interaction between the substance of the body and the aether.

A body at rest with respect of the aether will keep its state of rest in the absence of any pressure gradient. A body at constant speed with respect to the aether will have equal aether flow speeds at both its ends as long as the flow is laminar, that is, at relatively low relative speeds. Bernoulli equation states that the total pressure is equal at any point along a flow line and hence, supposing friction negligible, such a body will keep its state of motion indefinitely. While these two states may be described as quasi-equilibrium states, the acceleration of a body through the Torricellian space is essentially a transient phenomenon of non-equilibrium that results in the generation of an aether pressure gradient around it. Here, again, it is seen that an Archimedic-like force is born that acts opposite to the direction of the gradient that is, opposite to the direction of acceleration. While the body moves in the direction of the force and therefore the direction of the acceleration is in the direction of the force F_{action} , the inertial force is directed oppositely. This is the force that was perceived by Newton as a resistance to the change of the state

of motion of a body and that is known as inertia effect. It may be of interest to add here that a similar effect has been noticed in phenomena of fluid mechanics proper, where it was found that a body accelerated through a fluid behaves as if it had an increased mass, and that this apparent mass is felt even for cases when the respective fluid is frictionless. [21] A typical description of this effect is given as follows [22]:

“The motion of a sphere in an infinite ocean of an ideal fluid is therefore completely identical with the motion of the sphere in a vacuum if its mass is increased with that of an amount of liquid equal to half its volume.”

The present work then asserts that the very mass that the sphere is said in the above quote to manifest when moving in vacuum is in fact the result of the acceleration of the respective body through the fluid aether that fills the vacuum. Because the vacuum in the present theory is not that imaginary region of space that contains absolutely nothing, but the volume of the Torricellian space or that of the interstellar space that is filled by the aether.

The constant of inertia m_i can then be obtained from the identity of the two forces given by eqn. 17 and 20

$$m_i \cdot a = \nabla p \cdot d \cdot V \quad \text{Eqn. 21}$$

From which m_i is obtained as:

$$m_i = \frac{\nabla p}{a} \cdot d \cdot V \quad \text{Eqn. 22}$$

It can be seen from the last equation that the proportionality constant m_i indeed corresponds to a dynamical effect being a function of $\nabla p/a$, while it is also a function of the properties of the accelerating body, i.e. of the intensive quantity d , the absolute density of matter, and the extensive quantity V , its volume. The form of equation for m_i requires, however, a detailed calculation of the pressure gradient that a body generates when accelerating through the aether. A rough estimate from the studies of the movement of solid bodies through gaseous media would suggest that the aether pressure gradient that develops is constant for low speeds and becomes strongly dependent on the speed u of the body at high speeds. Eqn. 22 would then be of the general form:

$$m_i = f(u) \cdot d \cdot V \quad \text{Eqn. 23}$$

A discussion of the analytical form of the function $f(u)$ will be left for a future work.

Conclusions

The present work analyzed the consequences deriving from the fact that material bodies are permeated by aether. It was shown that a force exists in any region of space where a

gradient of the aethereal pressure is present. This force, Archimedic in nature and acting as a buoyancy force on the bodies immersed in the ocean of aether, was held accountable for the class of effects collectively known as gravitation. The magnitude of the force was demonstrated to be proportional with the local aether pressure gradient, and therefore to be zero in regions of space where aether pressure is uniform.

The origin of the aether pressure gradient was found in the radiation generated by thermally active hot bodies. It was shown that the radiation pressure from such bodies is pushing the aethereal substance away from the body, totally up to a certain limit, followed by partial expulsion within the rest of the volume of the body and further beyond its geometrical boundaries in the space around it. The condition of mechanical equilibrium between the radiation of the hot body and the aether was that the radiation pressure and the decrease in the aether pressure that it generates be equal at any point of space. This led to a mathematical relation for the dependence of the aethereal pressure with the distance from a hot body. The force of gravitation obtained by this theory was demonstrated to be consistent with that proposed by Newton regarding the law of dependence with the inverse square of the distance. This ensures that Kepler's laws of planetary motion are obeyed.

Newton's law of gravitation with its dependence on the masses of the bodies interacting gravitationally was shown to be unfounded and a new law was proposed that takes into account the total radiating power of the hot body, the macroscopic volume and the absolute density of matter of the second body, as well as the separating distance and the properties of the aether filling the respective space. It was shown that the present-day unit for the quantity of matter, the kilogram, besides being conventional, is both useless and unjustified. It was shown that mass and quantity of matter are different physical quantities. The dimension for the quantity of matter is m^3 and this result happens to come very close to the Cartesian view in which "extension constitutes matter" [23]. A more rational definition for the density of matter was proposed.

The new law of gravitation was discussed in relation to proofs from astronomy and it was shown that massive bodies in a cold state can not form planetary systems, the source of gravitational field being ultimately the thermal activity of such a body. It was shown that, in general, two cold bodies cannot be found to gravitate around each other, irrespective of how big is the amount of substance contained in their volume. This result is of peculiar importance for the theory advanced in this work as it bears the key to its validation. If two cold, non-radiating isolated bodies will ever be discovered gravitating around each other, this will represent a most assured proof of its invalidity. However, to the best knowledge of the author, such a system has not been evidenced yet.

A particular situation was discussed in which the radiation of a celestial body is so strong as to repel the aether totally from within its body and it was found that such an object corresponds to the concept of dark stars or to the modern term of black holes. It was shown that the visible light emitted by such celestial bodies does not escape from its source not due to the gravitational attraction between the massive body and the light, as it is purported today, but simply due to depletion of the transmitting medium, the aether, in the respective region.

It was shown that there is a fundamental difference between the concepts of mass and that of quantity of matter contained in a body and some consequences bearing on Newton's second law of motion were discussed. Mass was shown to be a dynamical quantity as it is the proportionality constant entering the equation for inertia effect. A relation was found giving the magnitude of this proportionality constant, also known as the inertial mass, in terms of dynamical as well as the intrinsic properties, intensive and extensive, of the accelerating body.

References

1. Isaac Newton, *Principia, The Mathematical Principles of Natural Philosophy*, translation into English by Andrew Motte, 1st American ed., (Daniel Adee, New-York, 1846), 73.
2. *ibid.*, 397.
3. Isaac Newton, *Four Letters from Sir Isaac Newton to Doctor Bentley, Containing Some Arguments in Proof of a Deity*, (R. and J. Dodsley, Pall-Mall, London, 1756). Second Letter from *Newton to Bentley, January 17, 1692/3*.
4. Isaac Newton, *Four Letters from Sir Isaac Newton to Doctor Bentley, Containing Some Arguments in Proof of a Deity*, (R. and J. Dodsley, Pall-Mall, London, 1756). Fourth Letter from *Newton to Bentley, February 25, 1692/3*.
5. Isaac Newton, *Opticks: Or, A Treatise of the Reflections, Refractions, Inflections and Colours of Light*, 2nd ed., (W. Bowyer, Prince's Arms, St. Paul's Church-Yard, London, 1717), Advertisement II.
6. Isaac Newton, *Principia*, *op. cit.*, 506.
7. Ionel Dinu, "What's behind Faraday's Magnetic Lines of Force", *Electric Spacecraft Journal*, Issue 41 (2006), 24-30.
8. Ludwig Prandtl, *Essentials of Fluid Dynamics, with Applications to Hydraulics*,

Aeronautics, Meteorology and Other Subjects, authorized translation in English (Blackie and Son, Ltd., Glasgow, 1952), 12.

9. James Clerk Maxwell, *A Treatise on Electricity and Magnetism*, (London: Macmillan and Co., 1873), 2:391.

10. John Henry Poynting, “Radiation in the Solar System: its Effect on Temperature and its Pressure on Small Bodies”. *Philosophical Transactions of the Royal Society of London*, 1903, Series A 202: 525-552.

11. Daniel R. Raichel, *The Science and Applications of Acoustics*, (Springer Science+Business Media, Inc., New York, USA, 2006), 61, 151.

12. Martin V. Zombeck, *Handbook of Space Astronomy and Astrophysics*, Second Edition (Cambridge, UK: Cambridge University Press, 1990), 25.

13. T. J. J. See, “Dynamical Theory of the Capture of Satellites and of the Division of Nebulae under the Secular Action of a Resisting Medium”, *Astronomische Nachrichten* Nr. 4341-42, Band 181 (1909), 333-350.

14. Martin V. Zombeck, op. cit., 31.

15. Enrico Fermi, *Thermodynamics*, (Dover Publications Inc., New York, 1936), 63-73.

16. R. Boehler, “High-Pressure Experiments and the Phase Diagram of Lower Mantle and Core Materials”, *Reviews of Geophysics*, 38 (2000), 221-245.

17. O. Lummer and E. Pringsheim, *Transactions of the German Physical Society* 2 (1900), 163. See also: Thomas Preston, *The Theory of Heat*, 3rd Edition, (MacMillan and Co., Ltd., London, 1919), 565.

18. Martin V. Zombeck, op. cit., 28.

19. J. M. Miller, A. C. Fabian, M. C. Miller, “A Comparison of Intermediate Mass Black Hole Candidate ULXs and Stellar-Mass Black Holes”, *Astrophys.J.* 614 (2004) L117-L120.

20. J. Michell, *Phil. Trans. Roy. Soc.*, 74 (1784) 35-57.

21. Ludwig Prandtl, op. cit., 180.

22. O. G. Tietjens, *Applied Hydro- and Aeromechanics*, translation in English by J. P. Den Hartog (McGraw-Hill Book Company, Inc., New York and London, 1934), 107.

23. E. T. Whittaker, *A History of the Theories of Aether and Electricity from the Age of Descartes to the Close of the Nineteenth Century*, (Longmans Green and Co., London, 1910) , p.4.

Figures

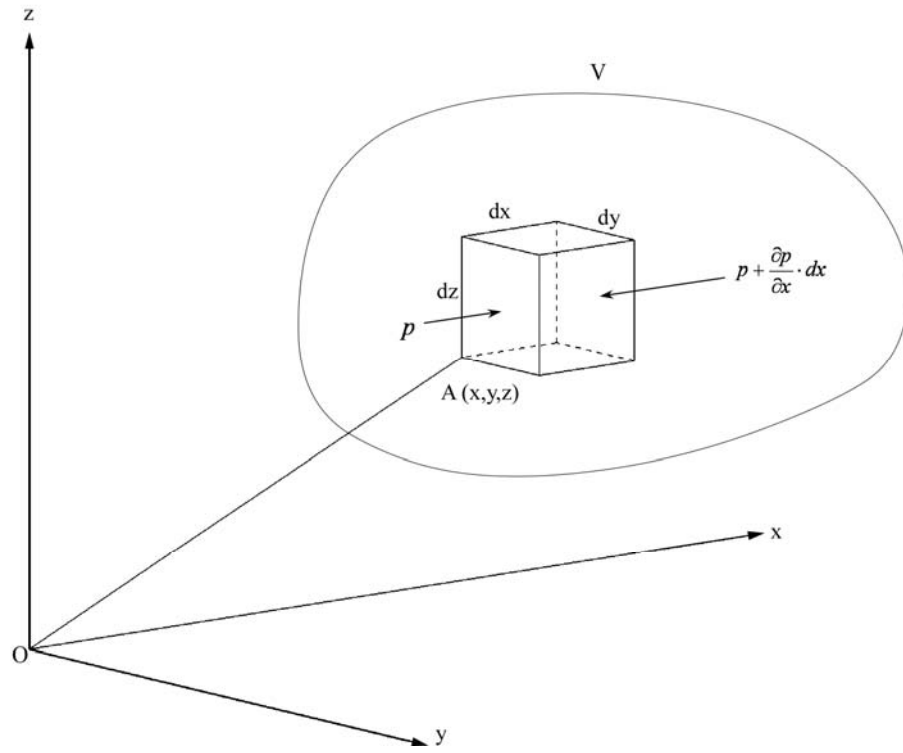

Fig. 1

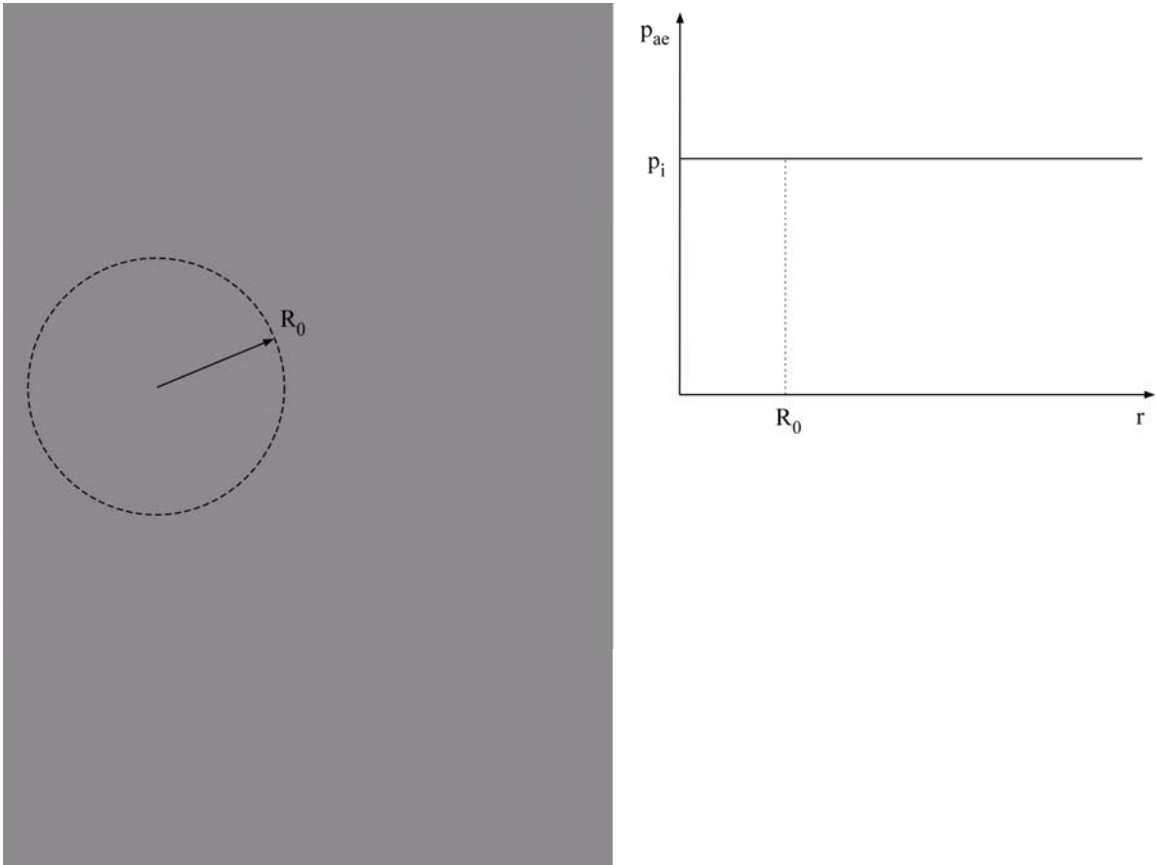

Fig. 2. The radial distribution of aetheral pressure around a cold body of radius R_0 situated in Torricellian vacuum or interstellar space. In the absence of any radiation from the body, the aether permeates its volume at uniform pressure, indicated in figure by uniform color. The aether pressure gradient is zero and so is the aetheral Archimedic force acting on any object situated in the neighborhood of the cold body. Such a thermally inactive body has no gravitational field. Two such bodies cannot form a bound system orbiting around each other. This is confirmed by the fact that no such system was discovered until now in the cosmic space.

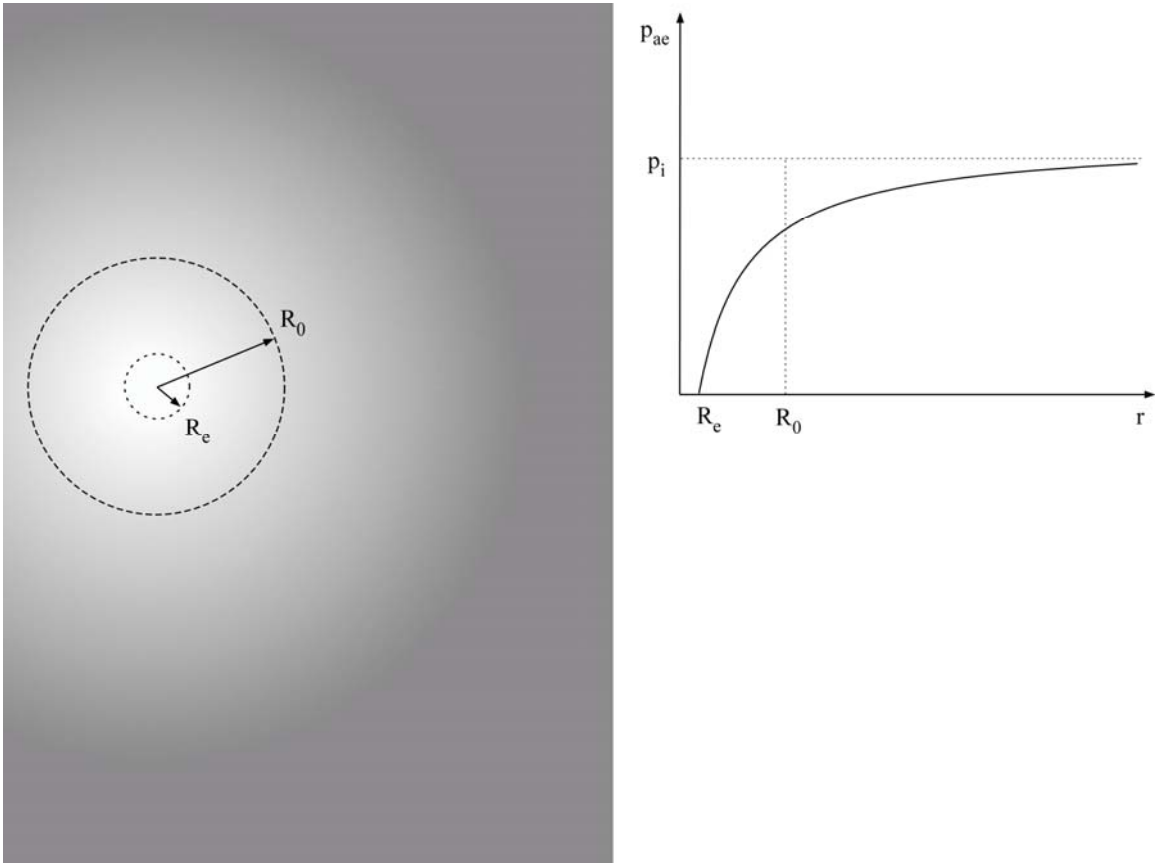

Fig. 3. The radial distribution of aetherial pressure around a hot body of radius R_0 situated in Torricellian vacuum or interstellar space. The radiation originating from the body exerts pressure on the surrounding matter including the aether. The aether is pushed away from the center of the hot body and further beyond its geometric boundary creating an aether pressure gradient indicated in figure by gradient color. The aether pressure is low in the vicinity of the body and approaches the interstellar value p_i at large distances from its center where the radiation pressure becomes negligible, according to eqn. 14. The hot body practically impinges on the aether radially in all directions and creates a region of decreased aether pressure in its neighborhood. Any object situated there is pushed towards the center of the hot body by the aetherial Archimedic force that is born within this region. Such a radiating body in the interstellar space generates a gravitational field and forms bound systems with other bodies.